

**FES/BarDyne
Technology
Transfer
Publication**

#10

Dr. Richard K. Tessmann, P.E.
Vice President
FES, Inc.
Stillwater, Oklahoma U.S.A.

Dr. Ing T. Hong, P.E.
President
BarDyne, Inc.
Stillwater, Oklahoma U.S.A.

Contamination Control of Aircraft Hydraulic Systems

Abstract

Particulate contamination is the major source of wear and failure in hydraulic systems. Furthermore, an aircraft hydraulic system is a very high performance system with a high risk both in human life and financial cost when failures occur while in flight. One of the most severe problems which must be addressed in designing an aircraft hydraulic system with high reliability is particulate contamination. Therefore, contamination control must be a major concern to the designers and maintenance personnel associated with the hydraulic systems on aircraft. Fortunately, however, contamination induced failures can be avoided or at least minimized if appropriate contamination control strategies are applied in the design and maintenance activities. This paper reveals the modern contamination control theories that allow the engineer to explore practical contamination problems through component sensitivity tests.

Introduction

While the potential for failure on high performance hydraulic systems such as are found on aircraft is greater than it is on hydraulic systems with lower performance, the power to weight ratio and the flexibility associated with hydraulic systems in general are much better than can be obtained with any other type of power transfer and control system. In addition, the risk to human life which is inherent to aircraft failure must be a serious consideration. The risk factor means that the reliability and life of all the system used to control the aircraft must be given a very high priority. It is very bad to lose an aircraft which may cost a considerable amount of money but it is much worse to lose a human life.

Every type of system which provides adequate power transfer and control has a unique set of reliability problems which must be addressed during a rigorous design and development effort as well as the on-going maintenance program. In the case of hydraulic systems, one of the most critical factors which effects life and reliability is particulate contamination. However, the contamination factor which has plagued aircraft hydraulic

systems for many years can be effectively addressed to eliminate almost all of the risk. In the past practice, the contamination problem was approached by merely specifying a filter which had been used previously or which had some perceived potential of lowering the contamination level of the hydraulic system. Very little attention was given to the actual performance of the filter in past applications or the contaminant sensitivity of the operating components involved in the hydraulic system. In addition, little design effort was expended in providing exclusion devices which would effectively reduce or eliminate the ingress of particulate material

In many cases, the filter may be specified as a 5 micron element as determined by some specification and then the contamination level may be specified by using a contamination class as defined by NAS 1638. However, when the actual test procedure for the filter element is explored, it will be found that the micron rating obtained can not be correlated to any system contamination level. Many filters used in aircraft hydraulic systems are evaluated per MIL-F-8815. This military specification dates from the mid 1960s to the mid 1970s depending upon which of the many variations of this specification is cited. The micron rating used in 8815 is commonly called an absolute rating and refers to the "largest hard spherical particle which will pass through the filter element under specific test conditions." The key word in this definition is spherical which implies that the particulate material to which the test element is subjected is spherical. The particulate contamination which becomes entrained in the fluid of an aircraft hydraulic system comes from several sources none of which produces spherical particles. Filters which are qualified by the old absolute rating system as exemplified by MIL-F-8815 are still being manufactured today and are used in many aircraft hydraulic systems. However, there is much more rigorous contamination control technology available today and it is effectively used by a great number of hydraulic system designers.

Background

In the late 1960s and early 1970s a new and more in-depth study of the contamination control technology was rigorously pursued by researchers at the Fluid Power Research Center located at the time at Oklahoma State University under the direction of Dr. E. C. Fitch. The results of that research produced concepts and test procedures for filters and other hydraulic components which not only provided extremely useful data but which also had a complete analytical foundation(1). Much of this progress was made possible by the advent of an effective automatic particle counter. The major problem which had to be solved in order to use these new automatic particle counters was that involved with calibration. Up to this point in time all particle size distributions which were measured from samples taken from a hydraulic system relied upon the microscope. The microscopic particle counting procedure, SAE ARP 598 involved a considerable amount of time and operator skill which made it very tedious. In addition, since the contaminant particles taken from a hydraulic system are irregular in shape, some visible dimension had to be selected since the person operating the microscope could not be expected to measure several dimension or performance calculations. Therefore, the common feature of a contaminant particle used by the technicians who relied upon the microscope was the longest dimension. When the liquid automatic particle counters arrived on the scene they used the diameter of a sphere with a projected area equal to that of the irregular particle. As shown in Fig. 1, there are various ways that have been developed over the years to describe an irregular shaped particle. However, by comparing the Projected Area Diameter, D_p , with the Largest Diameter, D_L , it can be seen that these two dimensions can be considerably different. Needless to say there was absolutely no agreement between a particle size distribution obtained through microscopic techniques and one developed from the same sample using an automatic particle counter. A great deal of work was expended which finally produced a calibration procedure for the automatic particle counter based upon a naturally occurring test contaminant with the normally irregular shaped particles (2, 3, 4). Using this procedure good agreement was attained and the data was very repeatable and reproducible. The procedure for the calibration of liquid

automatic particle counters later became ISO 4402. Armed with an accurate particle counter which could produce reliable data very quickly, the research vector could then be confidently defined.

Figure 1
Particle Size Description

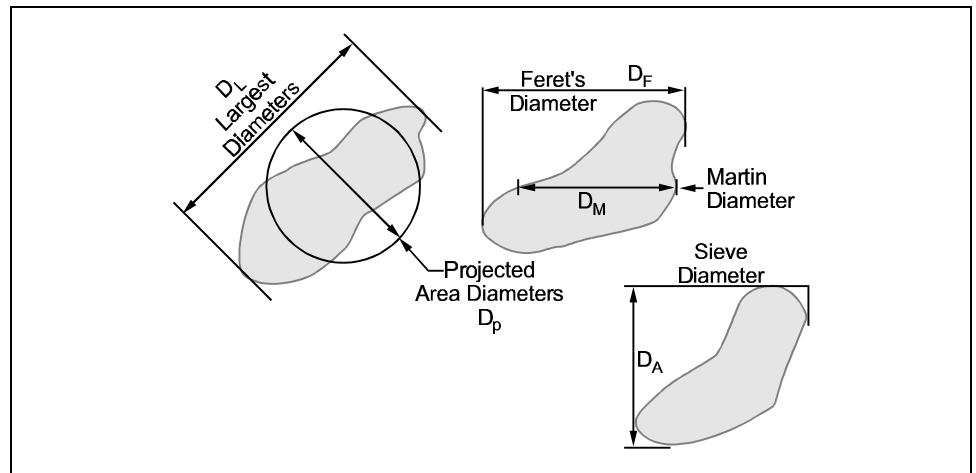

The contamination control concept which was developed during this early research effort and is still the best which can be offered is as follows

- The contaminant sensitivity of the hydraulic components must be determined either by qualified test procedures or by past experience.
- The component which is the most sensitivity will determine the contamination level which must be provided to attain the required reliability in the hydraulic system.
- The ingress rate of the system should be determined.
- The filtration provided must be consistent with the required contamination level and the rate of ingress.

This contamination control concept was eventually formulated into the contamination control balance (5) as shown in Fig. 2. As can be seen from this figure the component sensitivity, the duty cycle severity, and the fluid lubricity all work together to form the contaminant tolerance level of the most sensitive component. The tolerance level is not a single particle size distribution but includes many distributions and concentrations for which the system will exhibit the required liability or better. On the other side of the balance the contaminant which ingresses the system becomes the contaminant which exists in the fluid. The filter then will remove some of this contamination depending upon its particle size efficiency. In order to support an on-going contamination control program, the contamination level of the hydraulic system must be monitored through effective fluid analysis equipment. Then, for a given tolerance level the lower the contamination level the greater the life and liability of the system. It must be kept in mind that economics must be considered somewhere in the concept. In general it is expensive to achieve and maintain an extremely low contamination level. Therefore it is much better to use component with a good tolerance level than it is to attempt to maintain a low contamination level in the system.

Figure 2
Contamination Control Balance

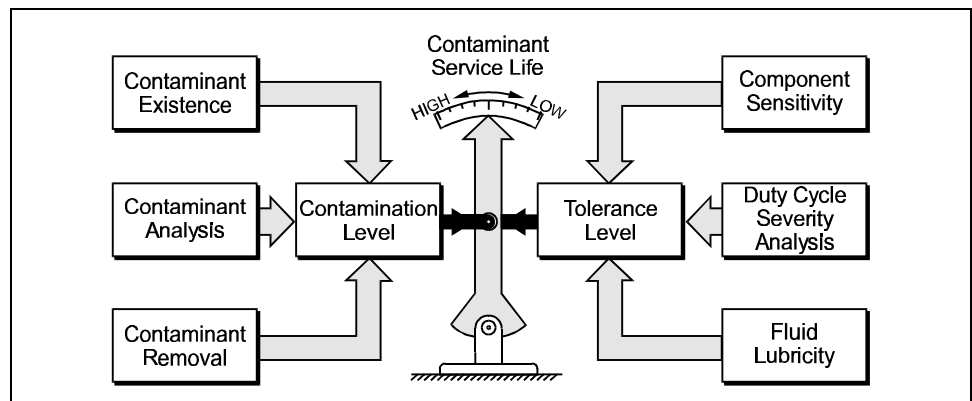

In order to implement the contamination control concept as revealed by the contamination control balance it is necessary to obtain information concerning the sensitivity of the component in the hydraulic system and the performance of the filter to be utilized. Since it is not possible to calculate the information required, test procedures have been developed to measure the data required to determine contaminant compatibility. The actual scope of the contaminant test procedures which have been developed and verified is much greater than can be covered in this paper. However, the filter performance test will be discussed along with the pump contaminant sensitivity test. The contamination evaluation of these components will provide examples of the procedures which can be applied. This presentation will conclude with a discussion of the methodology by which these test data can be used to produce a hydraulic system with high reliability and long service life.

Filter Evaluation

The performance of a filter element is usually evaluated in terms of three parameters—particle size efficiency, apparent contaminant capacity and pressure drop. A filter is a proportional device in that at some particle sizes it will only remove a portion of the contaminant which is subjected to it. In addition, a successful effort has not been reported in which the particle size efficiency of a filter element has been calculated based upon the parameters of the filtering medium. This statement is generally true for the other two parameters—apparent capacity and pressure drop. Therefore, it is necessary to conduct one or more tests to determine the magnitude of these parameters. A test which can be successfully used in this regard has been developed and is commonly referred to as the “multipass filtration test”. In order to have universal acceptance the multipass test requires the following:

1. The use of standard test dust
2. The use of a standard and qualified test system
3. The use of standard test conditions
 - Steady state flow and temperature
 - Constant and measured ingress rate of the standard test dust
 - Controlled fluid

The complete multipass filter test is described in ISO standard 4572. The rationale for the use of standard test dust is fairly apparent and needs little comment here. However, the requirement for a standardized test system which has been successfully qualified needs some explanation. In the fabrication of any test stand or test system it is mandatory that the condition imposed on the test component be accurately measured. In the case of the filter test system the filter must be exposed to the standard contaminant by the circulating fluid. The purpose of the qualifying evaluation is to insure that the contaminant that is injected into the test system is, in fact, carried to the test element and is not settling some place within the system or being ground up by the shear of the

pumping mechanism. The controlled fluid requirement is only for repeatability purposes. Since the pressure drop across the element is a direct function of the fluid viscosity, if different fluid are used different parameter values will be obtained for the element. It is not necessary to use the fluid specified by ISO 4572. However, it must be realized that a change of fluid will influence some of the filter test data.

The multipass filtration performance test actually consists of two separate and distinct circuits. One circuit is the filter test system while the other system is the contaminant injection system. A schematic showing both of these systems is given in Fig. 3. To help insure that contamination material will not settle in the reservoirs, both system have reservoir with conical bottoms and return line diffusers. In addition, both systems contain appropriate pumps, heat exchangers, and clean-up filters. ISO 4572 specifies a qualification procedure for both the contaminant injection system and the filter test system. The qualification procedure evaluates the capability of each system in the multipass test stand to maintain contaminant in suspension throughout the expected duration of a filter test at the lowest flow rate to be used. In operation, the contamination level of the contaminant injection system fluid is very high compared to the desired contamination level of the filter test system. In order to provide assurance that the test element is exposed to a constant level of new contaminant, a small flow stream (250 milliliters per minute) is taken from the contaminant injection system and put into the filter test system. It should be obvious that with a constant contamination level in the contaminant injection system and a constant injection flow rate, the rate of contaminant addition to the filter test system will be constant.

Figure 3
Schematic of Multipass Filter Test System

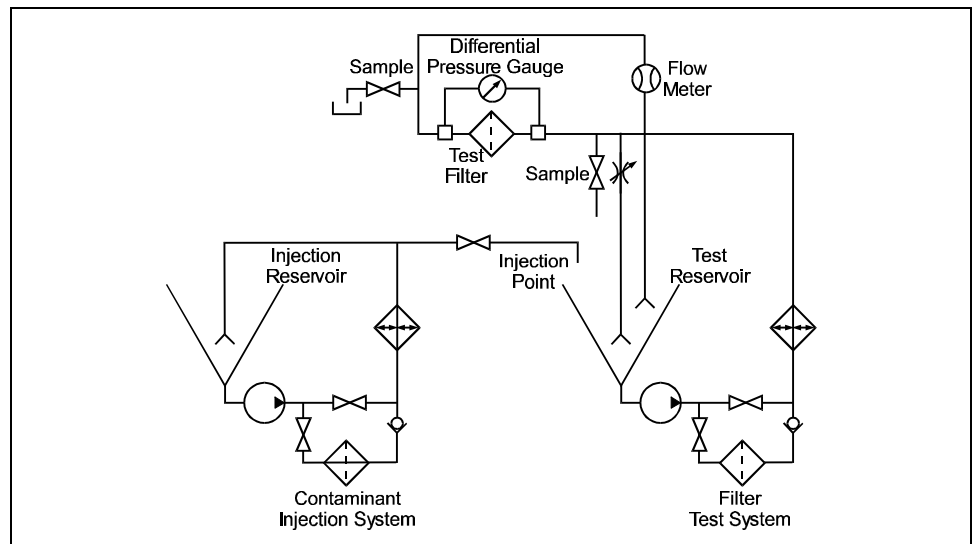

During a multipass test, the test filter is run at a constant flow rate, a constant temperature and a constant injection rate until a specified pressure drop is attained. The specified pressure drop is called the terminal pressure drop. The upstream and downstream contamination level is recorded at specific pressure drop points as determined from a measurement of the loading curve for the particular filter involved. The loading curve is a plot of the pressure drop across the test filter versus either time or amount of contaminant added to the filter test system. The upstream and downstream contamination levels are measured by counting the number of particles greater than several selected particle sizes per milliliter. These contamination levels can be measured by extracting samples at the required points and determining the particle distribution at a later time or by continuous in-line particle counting. In the case of in-line particle counting a dilution system must be included as yet a third system in the multipass test stand. The dilution system must be qualified by documenting through measurements the actual dilution attain by the system under the various condition associated with multipass filter testing. If fluid samples are extract, the sample containers must be certified clean by

ISO standard 3722. In all cases the particle counter utilized must be calibrated using the ISO standard procedure 4402.

An example of a data sheet which would be derived from a multipass filter test is shown in Fig. 4. As can be seen from this data sheet the test was conducted at a flow rate of 1.72 gallons per minute with an injection flow of 0.250 liters per minute. The average gravimetric level entrained in the injection system fluid was 278.335 milligrams per liter which is made up of full distribution of AC Fine Test Dust(ACFTD). The apparent contaminant capacity is determined by calculating the total amount of test dust which was added to the filter before it reached the terminal pressure drop. In this case the terminal pressure drop is 10 psid across the element while it would be 13.65 psid across the filter assembly. The contaminant capacity of this filter was 54.97 grams. The particle size efficiency of the test filter was evaluated for particle greater than 2, 4, 6, 10, 15, and 20 micrometer.

Figure 4
Filter Element Multipass
Test Report Sheet

Filter Element Multipass Test Report Sheet							
Filter I.D.:	EXAMPLE			Date:	8/1/96		
Lab:	FES, Inc.	Test #	1234	Flow Rate	1.72	GPM	R. H. (%):
Bubble Pt.:			Inches Water	Element Size (LxD) in.	10		x
Fluid ID:	MIL-H-5606			Fluid Temperature (°F):	100		6.5

Differential Pressures, psid		Injection			
		Initial	Final	Average	
Terminal:	10.00	Flow (lpm)	0.250	0.250	0.250
Housing:	3.65	Grav (mg/l)	265.110	291.560	278.335
Clean Assembly:	3.65				
Clean Element:	0.00				
Net:	10.00				

Dust Type:	ACFTD	Batch #:	4508G
System Volume :	1.63	Liters	Anti - Static Added:
Upstream Gravimetric Levels (mg/l):	Base	10.69	Final
			15.85

% Net Pressure	2.5 %	5 %	10 %	20 %	40 %	80 %	100 %
Assembly Pressure	3.90	4.15	4.65	5.65	7.65	11.65	13.65
Grams Added	1.53	2.54	19.72	23.94	33.07	49.06	54.97
Test Time, min.	22.02	36.46	283.39	344.11	475.19	705.00	790.00

Particle Distribution Analysis							
Particles per Milliliter Greater than Indicated Size (micrometers)							
Sample Point	Location	2	4	6	10	15	20
Background	Upstream	85.63	27.90	0.68	6.67	1.93	0.73
2 min	Upstream	15481.72	9153.48	5491.60	2178.68	679.20	233.72
	Downstream	1599.07	379.70	146.40	27.70	6.37	1.94
	Beta	9.68	24.11	37.51	78.65	106.62	120.47
10%	Upstream	13592.80	8182.12	4939.88	1992.28	633.48	212.52
	Downstream	175.70	45.20	22.12	7.98	2.38	0.70
	Beta	77.36	181.02	223.32	249.66	266.17	303.60
20%	Upstream	11584.68	6915.60	4113.32	1601.60	485.32	171.72
	Downstream	94.90	33.20	16.10	5.80	1.64	0.50
	Beta	122.07	208.30	255.49	276.14	295.93	343.44
40%	Upstream	11581.20	6918.12	4089.08	1550.40	461.32	147.32
	Downstream	72.20	26.90	11.30	3.40	0.80	0.22
	Beta	160.40	257.18	361.87	456.00	576.65	669.64
80%	Upstream	20362.12	11368.28	6368.68	2319.20	703.48	243.72
	Downstream	89.80	37.90	16.60	4.50	1.15	0.35
	Beta	226.75	299.95	383.66	515.38	611.72	696.34
Time Average Beta		114.23	219.99	280.63	334.79	374.18	428.31
Minimum Beta		9.68	24.11	37.51	78.65	106.62	120.47

ACFTD	Capacity: Apparent	54.97	g	Retained	53.93	g
-------	--------------------	-------	---	----------	-------	---

In the development of the multipass test, it was felt that a new term for the particle size separation characteristics of a filter should be defined. The term used for the efficiency parameter in the multipass test is "Filtration Ratio" which is often referred to as the "Beta Ratio" because the greek letter β is used to designate the filtration ratio. The filtration ratio is defined as the ratio of the number of particles per unit volume greater than a given particle size upstream of the filter to the number of particles greater than the same size in the same volume downstream of the test filter. The filtration ratio can be written in terms of the cumulative particle size efficiency as follows:

$$\beta_{\mu} = \frac{1}{1 - \epsilon_{\mu}} \tag{1}$$

where β_{μ} = Filtration ratio for particles greater than μ .
 ϵ_{μ} = Cumulative efficiency for particles greater than μ

At the bottom of the table entitled “Particle Distribution Analysis” in Fig. 4 there are two very important parameters—The time averaged beta and the minimum beta. As can be seen from the referenced table the beta ratio changes not only with particle size but also with pressure drop. Therefore, two ways are used to designate the beta ratio. The minimum beta is straightforward and refers to the lowest value of the beta ratio at any given particle size. On the other hand, the time averaged beta is more complicated. In order to calculate this parameter the beta ratios must be transform to the particle size efficiency by Eq. [1]. Then the time weighted average is calculated for the efficiency values at each sample point. The time averaged efficiency is then converted to beta ratio by the given formula.

It has been found that the downstream particle size distribution for a filter during the multipass test will follow a log-normal model. These models are called Beta Ten models because each test element is identified by the filtration ratio for particles greater than 10 μm . Fig. 5 shows the range of Beta Ten filter models ranging from β_{10} equals 1.01 to β_{10} equal 10000. As can be seen from this figure the higher the filtration ratio is the lower the downstream of the multipass filter test. It is assumed that the closer the field environment approaches the conditions imposed during the multipass test, the closer the system contamination level in the field will approach the beta ten model.

Figure 5
Beta Ten Filter Models

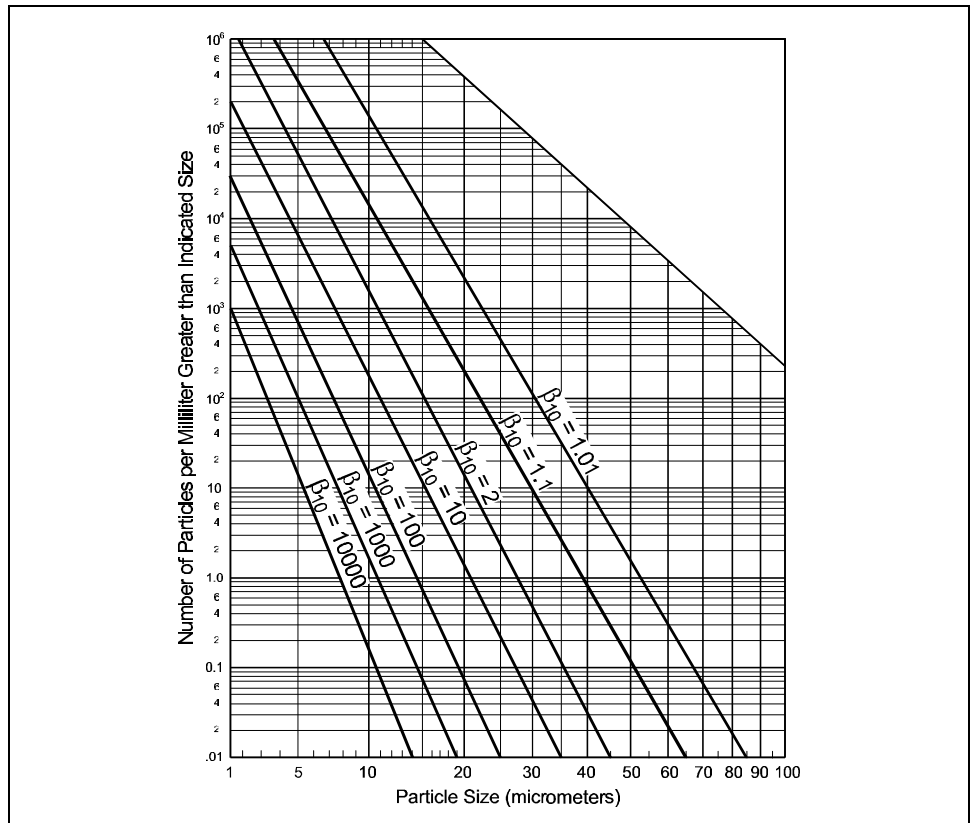

Pump Contamination Sensitivity

In the technology normally called contamination control the wear caused by the presence of particle contamination is termed contaminant tolerance or contaminant sensitivity. There are two factors involved in contaminant sensitivity—one involves the actual destruction of the surfaces of the components while the other involves the impediment to motion or flow. The destruction of the internal surfaces is usually measured by a degradation in the performance of the component and is called contaminant wear (6,7,8). The motion or flow impediment is termed contaminant lock. In this paper the contaminant sensitivity of a fixed displacement hydraulic pump is used as an example for the contaminant sensitivity procedures. In such a component as a constant displacement pump motion impediment is not normally encountered and therefore will not be discussed further in this paper.

Contaminant sensitivity is defined as the performance degradation of a fluid component in terms of contaminant exposure. The performance degradation versus particle exposure can then be interpreted in terms of contaminant tolerance and contaminant life. Contaminant life depends primarily upon three factors:

- The severity of the operating conditions such as pressure, speed and temperature.
- The contamination level of the circulating fluid
- The contaminant sensitivity or contaminant tolerance of the system components

In order to assess contaminant sensitivity it is necessary to perform a contaminant sensitivity test. The pump contaminant sensitivity test is given by NFPA Recommended Standard T3.9.18 R1-1986 entitled “Method of Establishing the Flow Degradation of Fixed Displacement Hydraulic Fluid Power Pumps When Exposed To Particulate Contaminant. This contaminant sensitivity test, like all contaminant sensitivity test procedures development in the 1970s and early 1980s at the Fluid Power Research Center, depend upon a qualified test system that allows the component to be reliably exposed to increasing sizes of contaminant while the selected performance parameter is monitored. In the case of a fixed displacement pump the selected performance parameter is output flow measured at a constant speed with a constant pressure applied. The qualification procedure outlined in the test document certifies that the test facility is capable of exposing the test pump to a specified contamination level for a designated time without permitting the contaminant to settle out of the flow stream. The qualification requirement is very important and demands a certain amount of design expertise.

A schematic of the test circuit needed for a contaminant sensitivity test on a fixed displacement pump is shown in Fig. 6. The reservoir is required to have a conical bottom and the fluid entering the reservoir must be diffused below the surface of the fluid. Provisions are made to either pressurize the reservoir or use a charging pump to insure adequate pressure at the pump inlet. The injection reservoir is constructed as shown in Fig. 6. The heat exchanger is either a one pass or a two pass unit and is mounted vertically with the fluid entering the bottom and circulating through the tube side. The load valve normally used is a simple needle valve configuration.

Figure 6
Schematic of Contaminant
Sensitivity Test System for Fixed
Displacement Pump

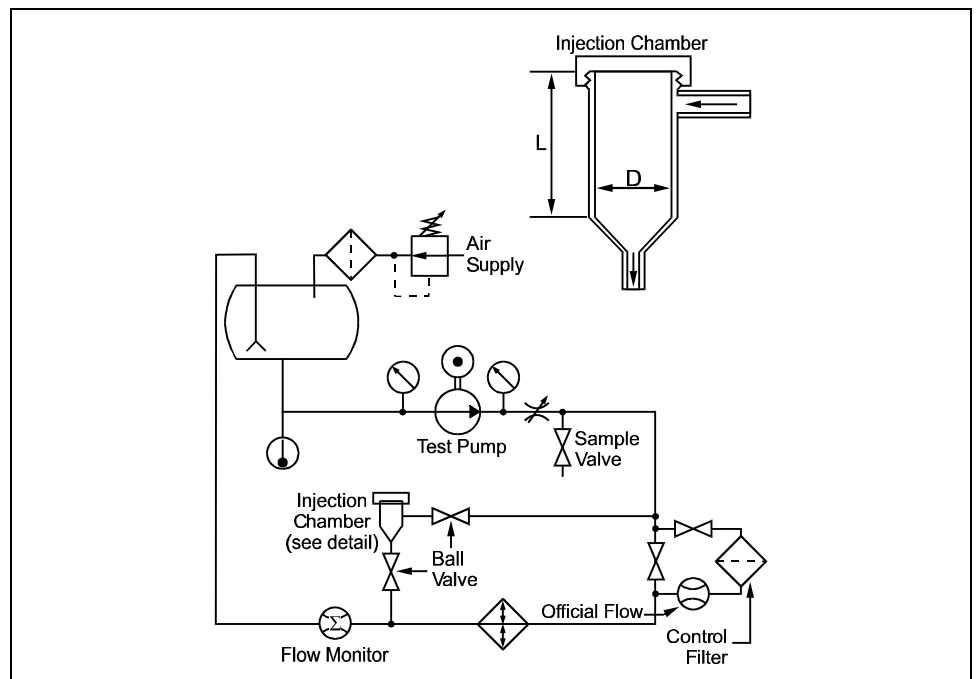

The contaminant sensitivity test procedure is conducted as indicated in the flow chart shown in Fig. 7. Research which was conducted on the contaminant sensitivity test revealed that in order to obtain useful results on a wide spectrum of pumps and maintain reasonable wear rates it was necessary to expose the pump to a gravimetric level of 300 mg/l for each size range. The size ranges for the test are 0-5, 0-10, 0-20, 0-30, 0-40, 0-50, 0-60, 0-70, and 0-80 micrometers. Experience has shown that many pumps are capable of being exposed to all of the size ranges at the specified 300 mg/l while sustain only slight damage. However, some pumps will exhibit excessive flow degradation after only the 0-30 micrometer exposure.

During the test, while the pump is operated at rated conditions as prescribed by the pump manufacturer, the 0-5 micrometer slurry is injected into the test system and the pump is operated for 30 minutes at this exposure or until the flow remains constant for 10 minutes. At this point, the fluid is circulated through the filter system until the contamination level is less than 10 milligrams per liter. The injection, exposure and filtration sequence is continued through the size ranges until the flow rate decreases to less than 70% of the rated flow or until the 0-80 micrometer size range has been injected. The flow degradation ratio is found by dividing the final flow after each injection is filtered out by the rated flow. The flow degradation signature of the test pump is obtained by plotting the flow degradation ratio versus the upper limit of the contaminant size range of the corresponding injection as shown in Fig. 8. The flow degradation signature is one method of evaluating the contaminant sensitivity of the test pump.

Figure 7
Flow Chart of Pump Contaminant Sensitivity Test

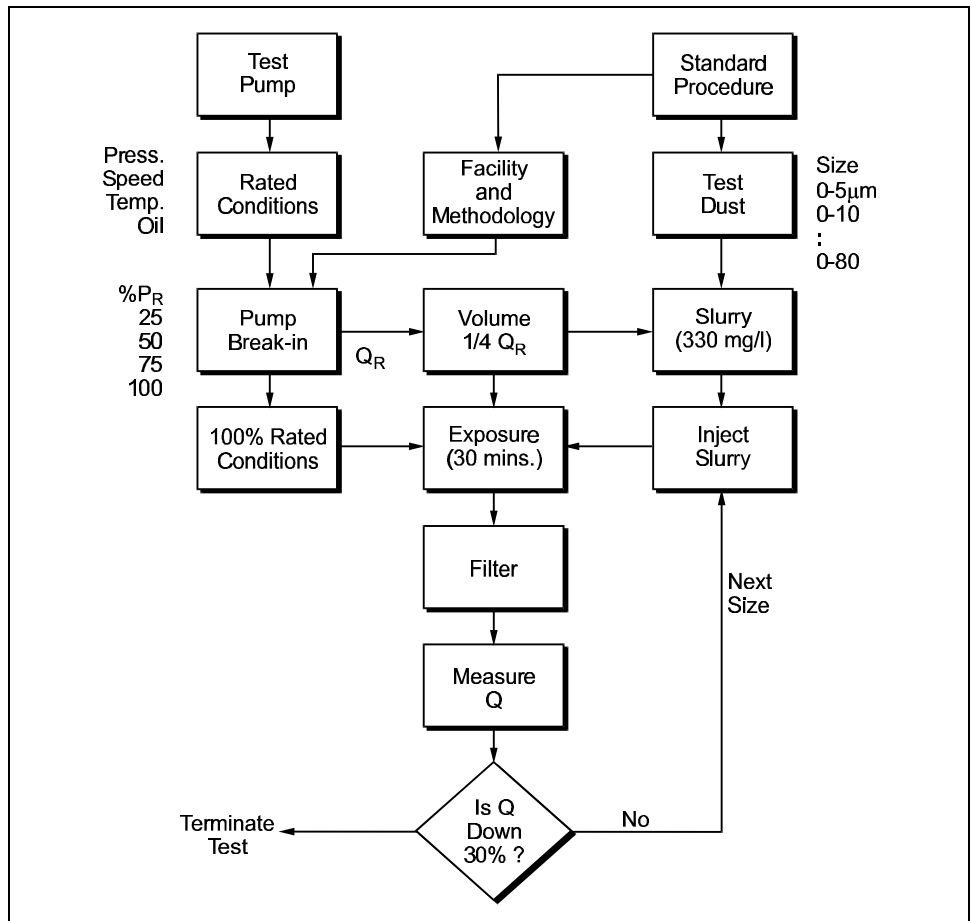
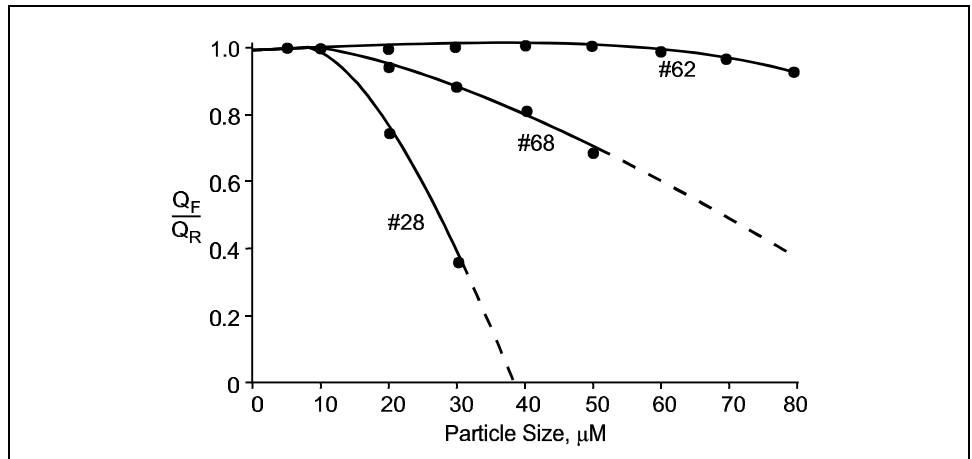

Figure 8
Flow Degradation Signature of Typical Pumps



Filter Selection

The end result of all contaminant testing is to provide information which can be used to not only obtain better components but also to be sure that the filter selection process produces a filter which will provide adequate life and reliability from the system. This can be accomplished by determining the contaminant tolerance profile for a specified life of the pump. A rigorous treatment of the calculation for establishing the contaminant tolerance profile is beyond the scope of this paper. In general, however, the performance degradations obtained for each contaminant exposure during the contaminant sensitivity test are utilized to obtain the contaminant sensitivity coefficients for the component at each of the particle size ranges. The contaminant exposure rate and

the particle destruction rate are taken into account in determining the contaminant wear sensitivity coefficients. This is a complex series of calculations because of all the factors involved in one exposure and the fact that the effect of one particle size range on each of the others must be evaluated. However, once a set of contaminant wear coefficients have been found they can be used to assess the contaminant service life of the component when operating at the test conditions and exposed to a given contamination level.

The contaminant tolerance profile describes the maximum particle size distribution level that can be continuously exposed to the pump without degrading its performance more than a designated amount during a specified period of time (say 1000 hours, for example). The tolerance profile is constructed by finding several different particle size distributions that produce the same contaminant life as determined by the contaminant sensitivity calculations. By definition, the contaminant tolerance profile is the locus of tangency points associated with the particle size distribution lines that yield the same contaminant life. A partial construction of a tolerance profile is given in Fig. 9. The profile is such that any contamination level with a particle size distribution which is tangent to the contaminant tolerance profile will provide a contaminant service life equal to the service life associated with that profile.

Figure 9
Partial Contaminant
Tolerance Profile

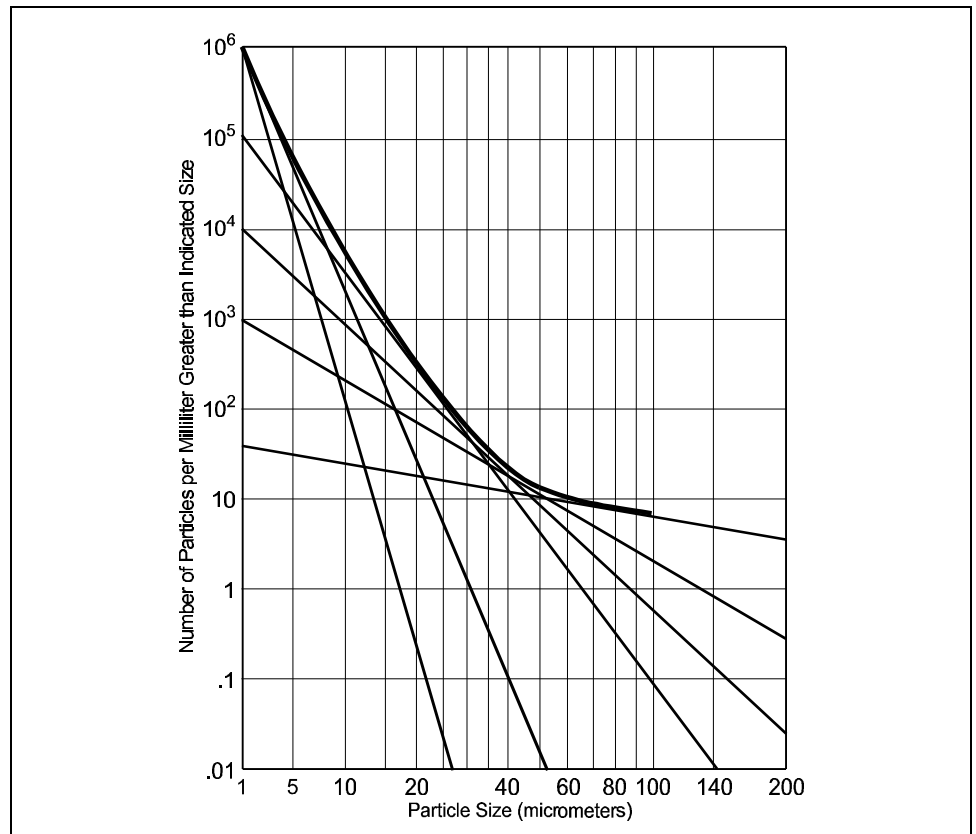

The contaminant tolerance profile can be used then to find the omega rating. The Omega Rating Concept is actually an extension of the contaminant tolerance profile technique. Once the pump contaminant sensitivity test is conducted the flow degradation signature and the contaminant tolerance profile both reveal the overall sensitivity of the test pump. The omega rating utilizes both the contaminant tolerance profile and the Beta Ten Filtration Models introduced earlier in this paper. Both the Beta Ten Filter Models and the contaminant tolerance profile can be plotted on a log-log² graph as shown in Fig. 10. When this is accomplished the Beta Ten Model which is tangent to the contaminant tolerance profile in the actual Omega rating. For the example shown in Fig. 10 the curved line represents the contaminant tolerance profile of a given fixed displacement pump. It can be seen that the Beta Ten Model designated 1.1 is a little below the tangency point of

the profile. Therefore, the Beta Ten Model which would be tangent to this particular profile is approximately 1.08. From this analysis then the Omega Rating for the example pump is 1.08 and it is prudent to select a filter with a beta ratio for particle greater than 10 micrometers of 1.08 to protect this pump.

Figure 10
Omega Rating Concept

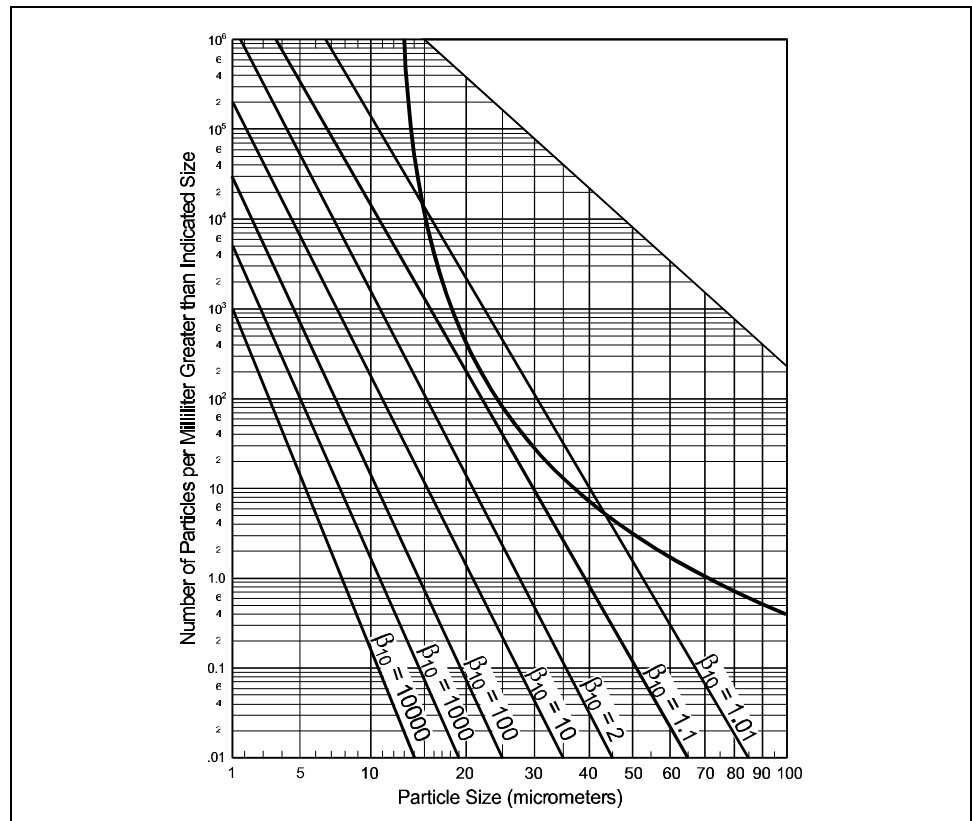

As an example of the effect of contamination on aircraft hydraulic components, tests have been conducted on a closed center, three position servovalve which are reported here. In clean environment, the valve performed is shown in Fig. 11. In this figure flow from work port A is shown on the right side while flow from work port B is shown on the left. When the servovalve was exposed to a contaminated environment, the hysteresis increased until the spool locked as shown in Fig. 12. In this case the spool locked in the centered position and therefore no flow was allowed to pass through the valve. However, other valve may lock in any position due to contaminant particles. In exploring the contaminant lock phenomenon it has been found that the increase in hysteresis is a function of both the particle size distribution and the concentration of particle similar to the contaminant wear mode as shown in Fig. 13. As can be seen from this figure, the servovalve tested exhibited little effect at any concentration of contamination composed of particles in the ranges of 0-5 micrometers and 0-10 micrometers, however, when exposed to various concentrations of 0-20 micrometer size range the valve revealed a sensitivity which must be considered in the system design. The servovalve can be evaluated in a manner similar to the fixed displacement pump illustrated earlier in this paper to produce a contaminant tolerance profile and an omega rating. Three valves are used here as examples of the sensitivity of this type of component as shown in Fig. 14. The valve designated as valve B exhibited an omega rating of approximately 100 while both A and C were much more sensitivity with an omega rating of about 5000. This means that the filter needed to produce reliable operation using valves A or C must be significantly more efficiency than that required by valve B.

Figure 11
Servovalve Performance
in Clean Oil

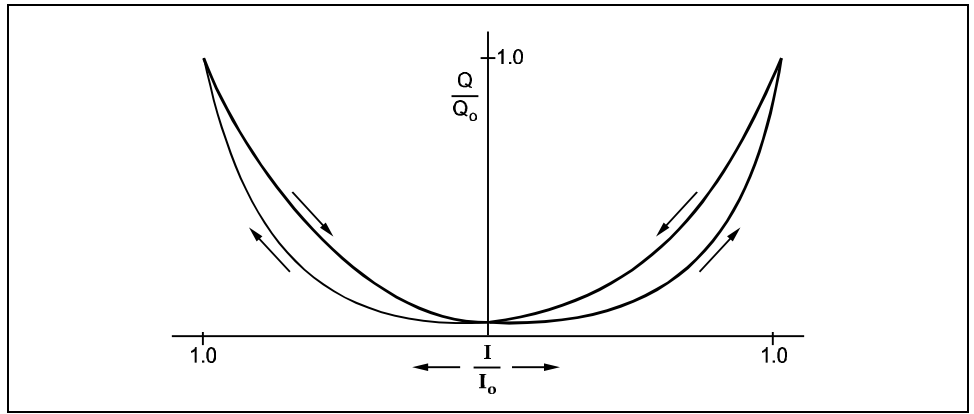

Figure 12
Servovalve Performance in
Contaminated Oil

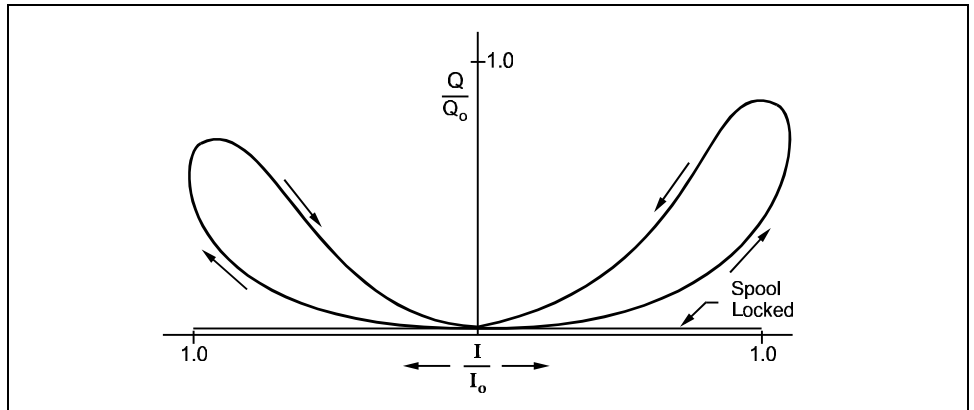

Figure 13
Measured Hysteresis Increase for
Servovalve Exposed to
Contaminated Oil

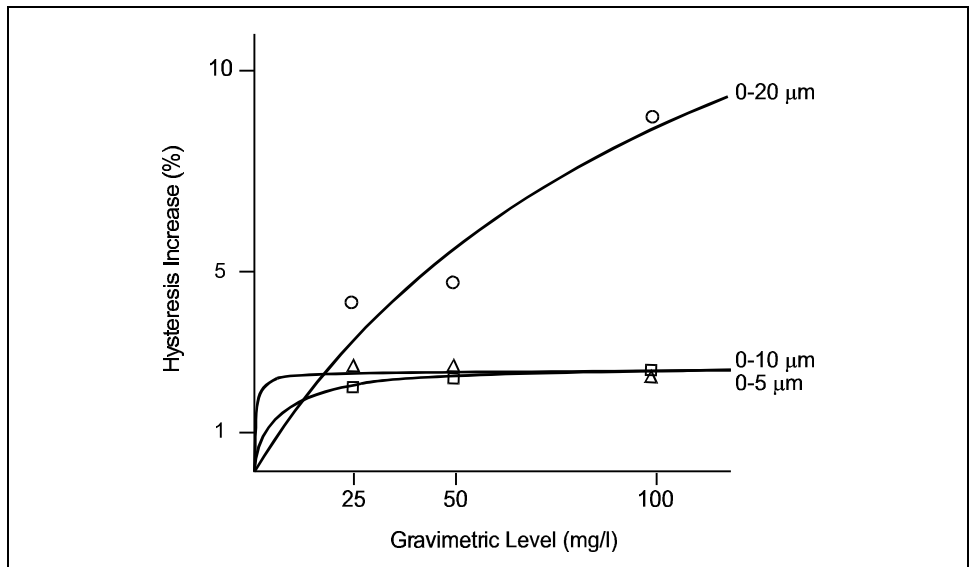
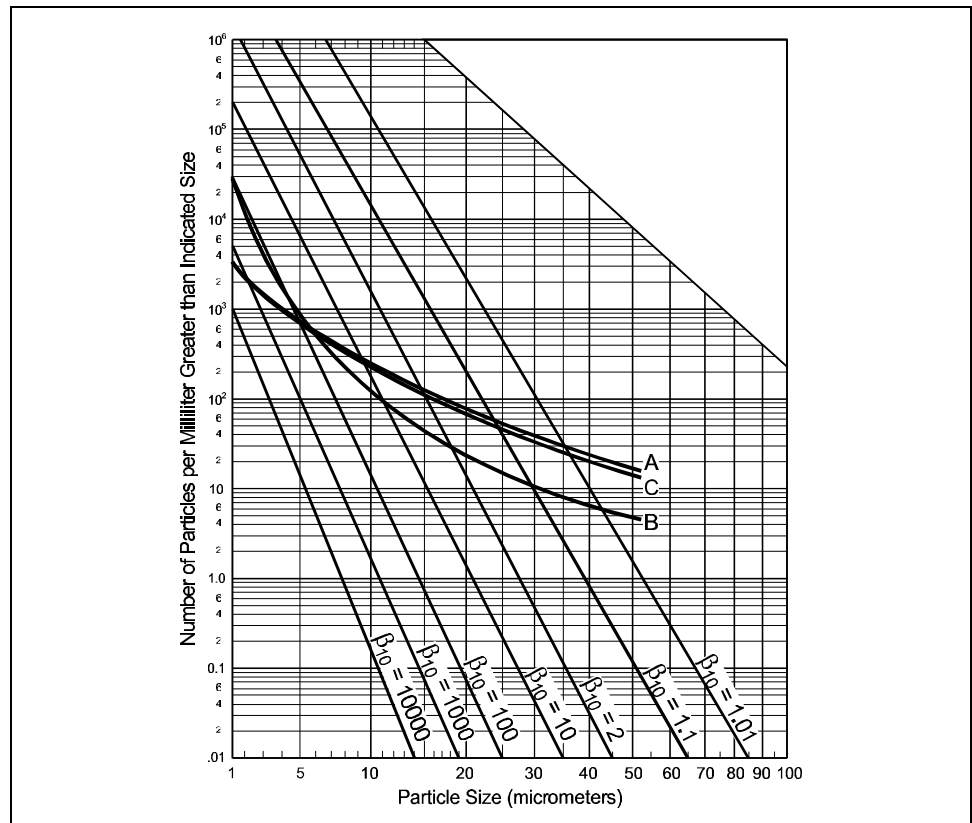

Figure 14
Contaminant Tolerance Profiles and
Omega Rating for Example
Servovalves



Conclusions

There can be little doubt that the life and reliability of an aircraft hydraulic system is a very serious consideration in the design development of the aircraft. The cost in terms of both money and human lives dictates that the reliability of all aircraft systems must be extremely high. Approximately 70% of all failures in hydraulic systems can be attributed to particulate contamination. Therefore, high reliability in the aircraft can not be attained without first achieving high reliability in the hydraulic system and this can not be accomplished without adequate contamination control. There are essentially four ways of evaluating the contamination control of an aircraft hydraulic system. One way, of course, is to build the aircraft and flight test it. However, this is a very expensive way in terms of both money and human life of determining the reliability of an aircraft hydraulic system. The second approach is to utilize a hydraulic system simulator. Again this is an expensive proposition and may damage the simulator. A third method is to use the design and analysis program, such as HyPneu, which has been used successfully to evaluate the performance of the hydraulic system. Finally, the approach suggested in this paper can be utilized. The test procedures are available for accelerated contamination testing of the hydraulic components along with interpretation methodology which can be applied to select compatible hydraulic components. This paper has illustrated techniques whereby the filter performance and the contaminant sensitivity of the hydraulic components can be evaluated and compared in such a manner that the best filter can be selected based upon the requirements of the other components in the system. The methodology presented has been used with great success in many applications including aircraft hydraulic systems. In addition, the contaminant sensitivity of servovalves has been illustrated and discussed. The contamination control balance as presented herein has been shown to be a direct and rigorous approach to contamination control and can be utilized by every system designer for his system.

References

1. Fitch, E. C., *Fluid Contamination Control*, FES, Inc., Stillwater, OK., 1988.
2. Bensch, L. E., "International Survey Of Automatic Particle Counter Calibration," *BFPR Journal*, 72-RQ-5, FPRC/OSU, Stillwater, OK, Oct 1972, 105-128.
3. West, G. C., *Conversion of Spherical Calibration to AC Fine Calibration*, Application Note No. 3, HIAC, Div. of Pacific Scientific Co. 1974.
4. Roberts, G. A., "Particle Counting: An Analysis of the Problem of Calibration," *BFPR Journal*, P75-12, FPRC/OSU, Stillwater, OK, Oct 1975.
5. Fitch, E. C., "The Contamination Control Balance", *BFPR Journal* Vol. 11, No 1, FPRC/OSU, Stillwater, OK, Oct 1997.
6. Wolf, M. L., "*Contaminant Particle Effects on Pumps as a Function of Size, Type, and Concentration*", M. S. Thesis, FPRC/OSU, Stillwater, OK, 1965.
7. Tessmann, R. K., "Contaminant Wear in Hydraulic and Lubricating Systems," *BFPR Journal*, FPRC/OSU, Stillwater, OK, Oct. 1975
8. Hong, I. T. and Fitch, E. C., "Wear of Gear Pump Under Abrasive Fluid Conditions," *Proc. Of NCFP*, National Conference on Fluid Power, Chicago, IL, Nov 1985, 1-7.